



**TUBAF**  
Die Ressourcenuniversität.  
Seit 1765.

**XERION**  
BERLIN • LABORATORIES



Institut für Keramik,  
Feuerfest und  
Verbundwerkstoffe

# Development of 3D Printed Steel-Ceramic Composites for High-Performance Refractory Components

**Dipl.-Ing. Patricia Kaiser**

Supervisors: Prof. Dr.-Ing. habil. Christos G. Aneziris  
Dipl.-Ing. Piotr Malczyk  
M.Sc. Serhii Yaroshevskiy



Freiberger Feuerfestforum  
13.12.2023

**#tubaf**



## Problem:

Increased utilization of secondary fuels facilitates corrosion of the furnace lining



## Solution

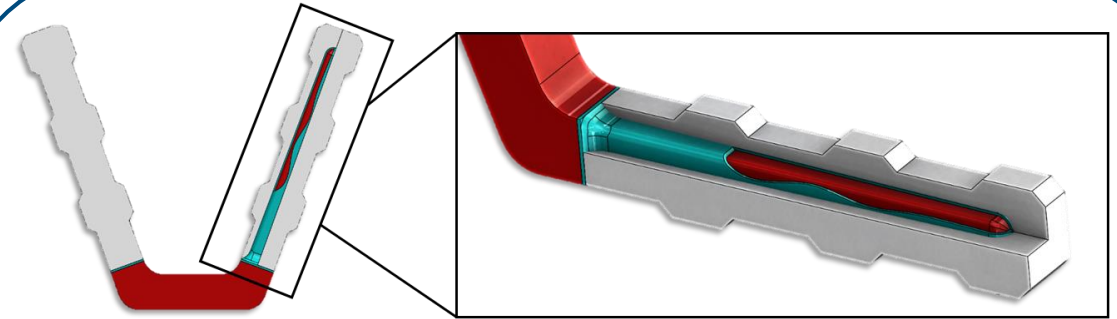

- Anchor system with multifunctionality
- Combined use of materials by FFF technology

### Material gradient of the system

**Steel**  
mechanical and  
physical properties

**Ceramic**  
corrosion resistance



## Filament Recipe

### Ceramic/Composite Solid Phase



### Thermoplastic Binder

#### Filament 1:

AR78 spinel

+

3 wt.% TiO<sub>2</sub>

#### Filament 2:

60 vol.% 316L stainless steel

+

40 vol.% AR78 spinel

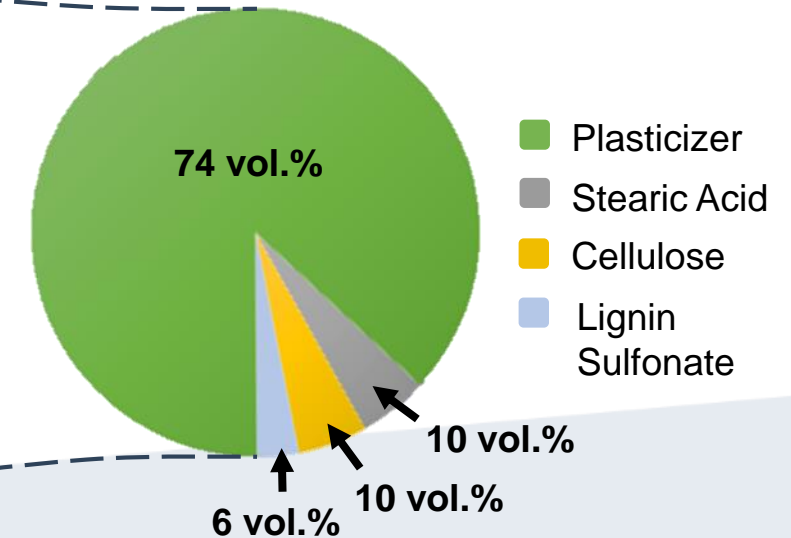
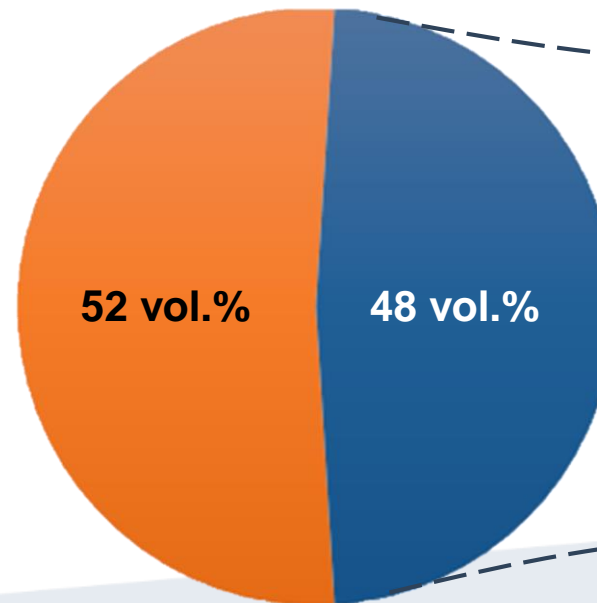

Patent: Aneziris, Malczyk, Yaroshevskiy, DE 10 2022 001 070.4, 29.03.2022



Printing

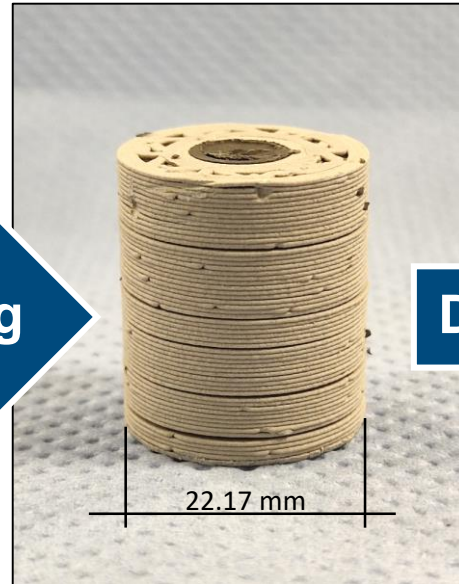

Debinding



Sintering

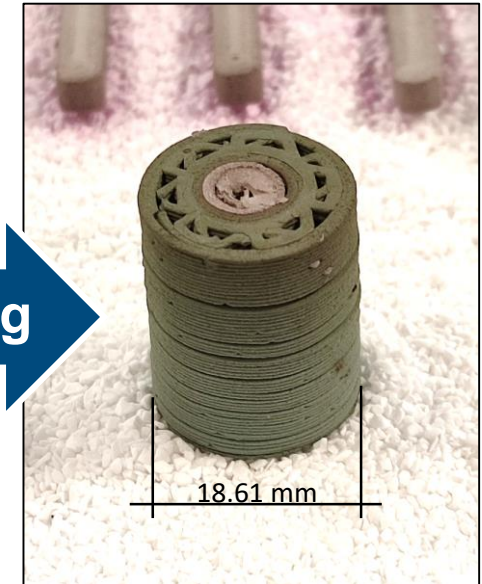

- Two individually controllable printheads (XERION Fusion Factory 3D Dualprinter)

- Debinding up to 450 °C (5 Steps) in **oxidizing** atmosphere

- Sintering up to 1400 °C (4 Steps) in **argon** atmosphere

based on Yaroshevskiy et al., Ceramics 2023



## Mechanical Properties

AR78+3TiO<sub>2</sub>

316L/40AR78

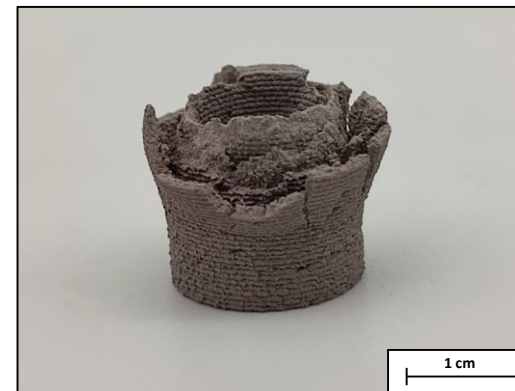
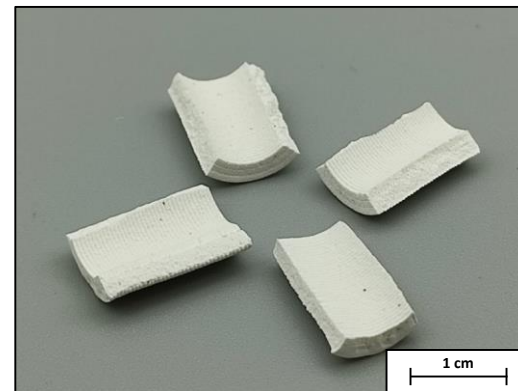
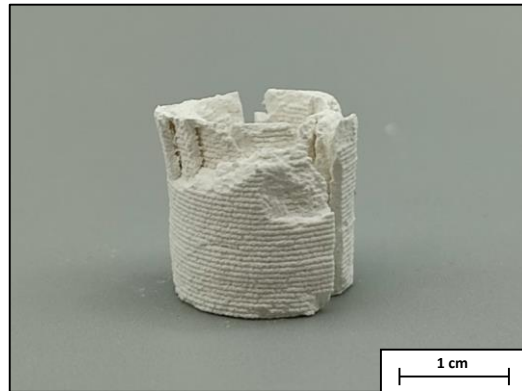

		$F_{\max}$ in N
Compression mode		2596.7
Splitting tensile mode		250.5

		$F_{\max}$ in N
Compression mode		1139.8
Splitting tensile mode		102.9





## Mechanical Properties

AR78+3TiO<sub>2</sub>

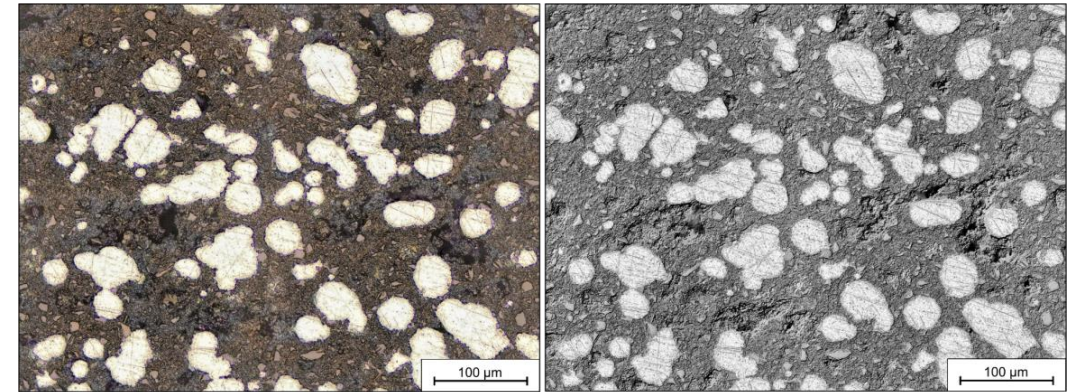
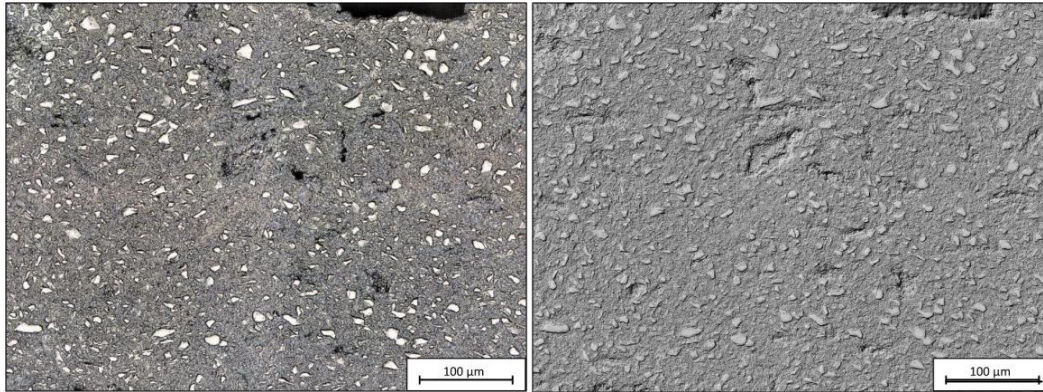
316L/40AR78

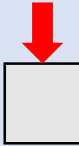
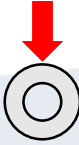

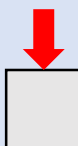
		$F_{\max}$ in N
Compression mode		2596.7
Splitting tensile mode		250.5

		$F_{\max}$ in N
Compression mode		1139.8
Splitting tensile mode		102.9



## Investigation of the Interface Layer

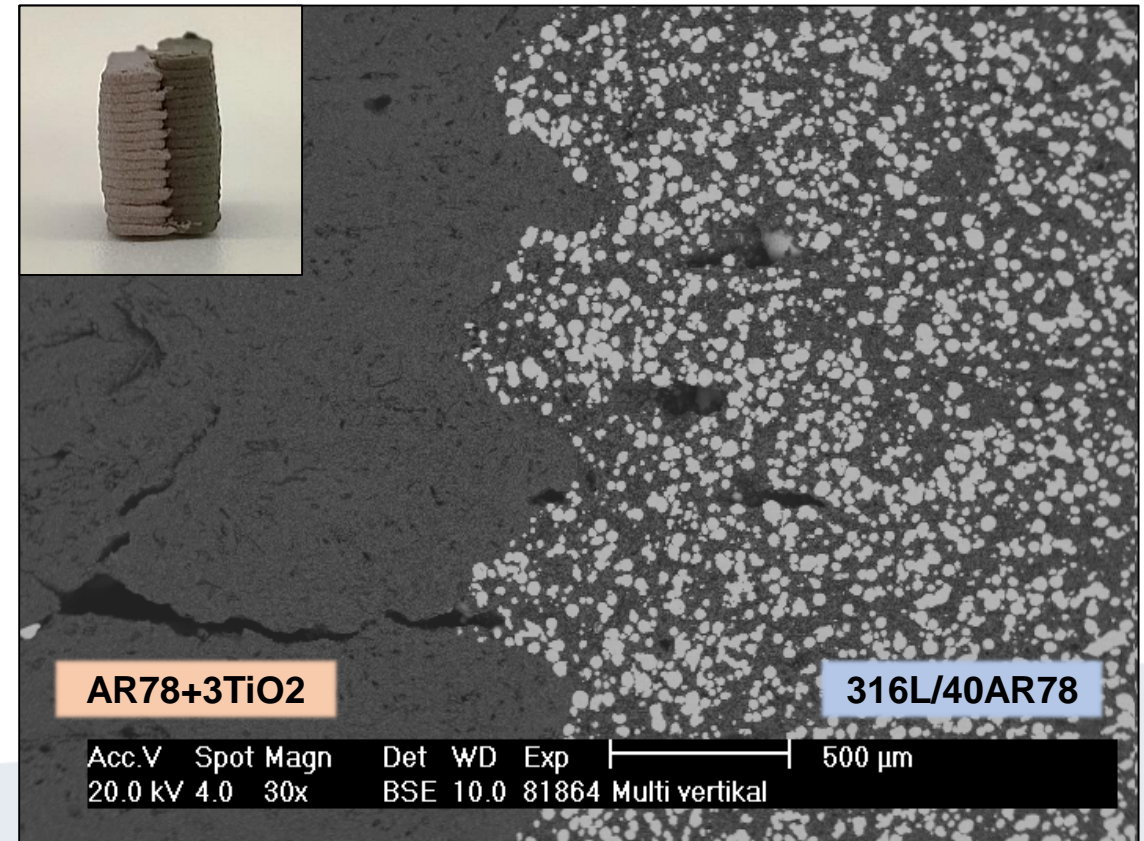
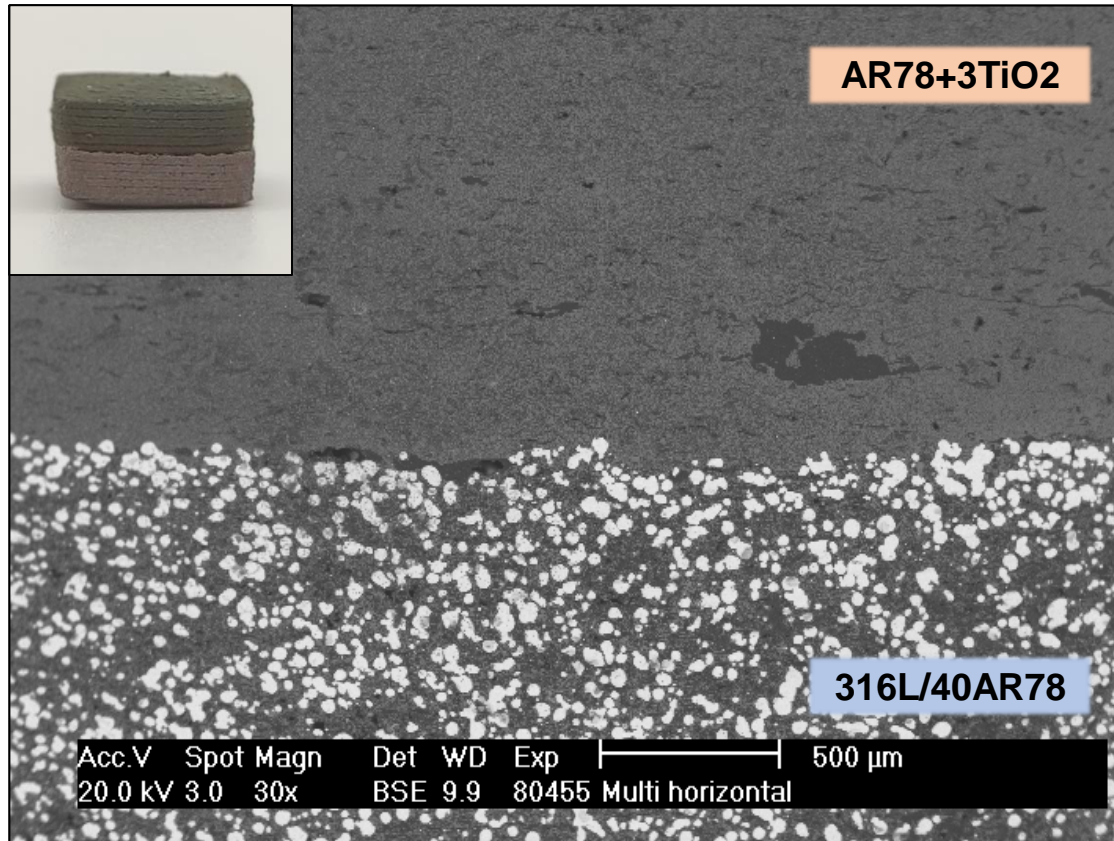



## Before Corrosion

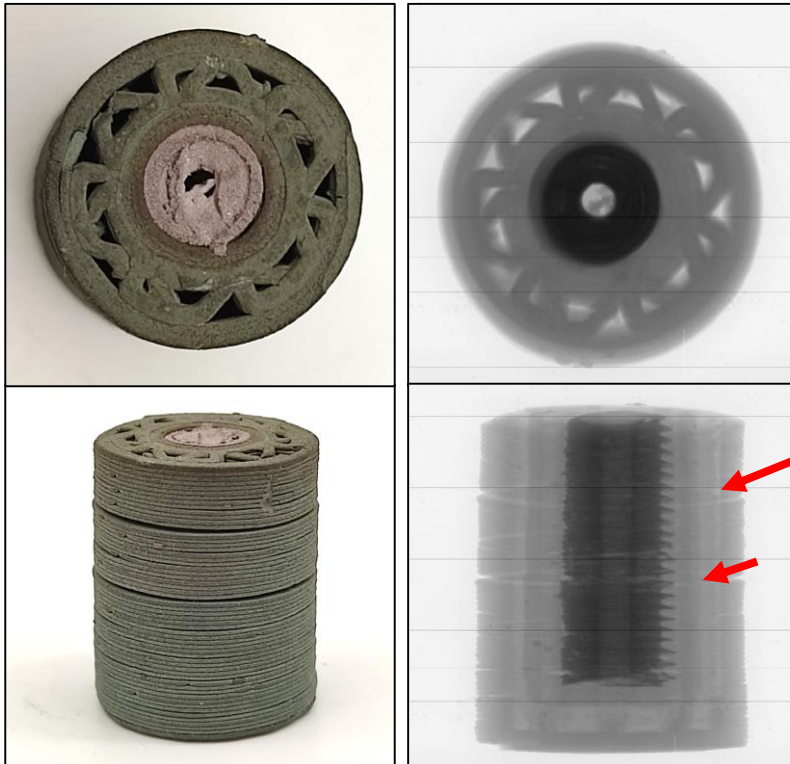

## Corrosion Test

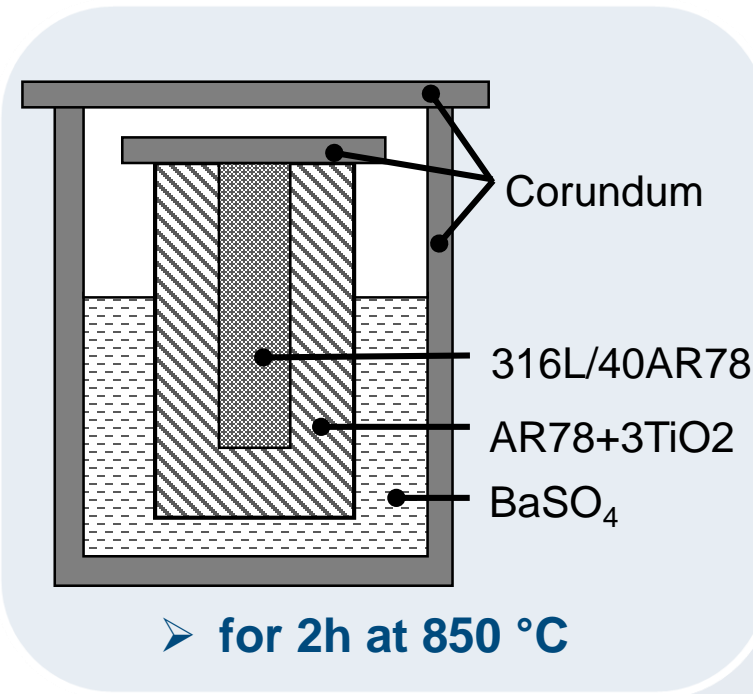

## After Corrosion

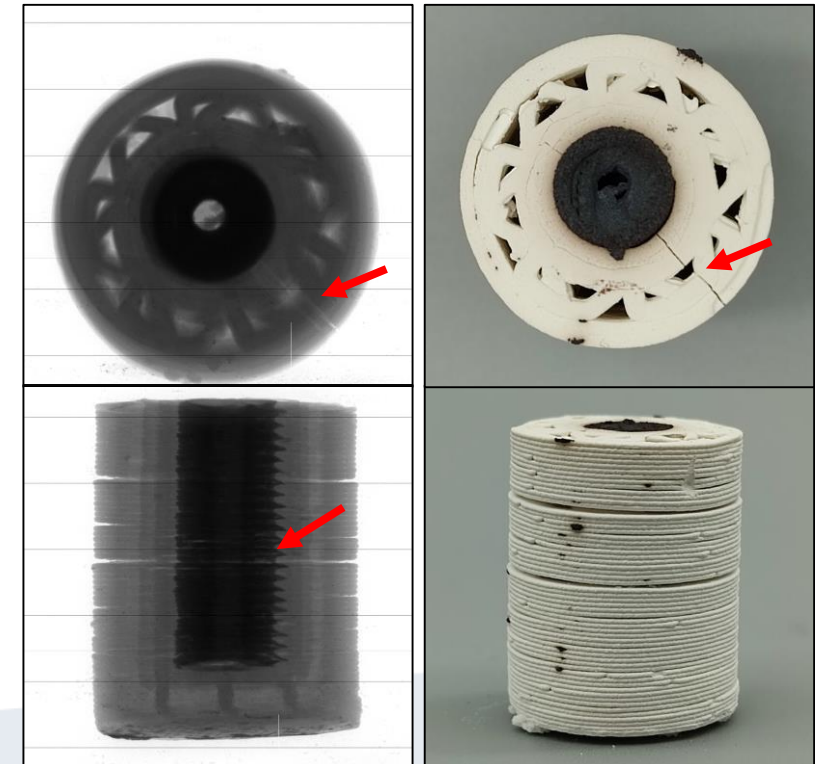



## Conclusion

- Sufficient stability of manufactured filament for the printing of single and multi-material samples
- Successful debinding without utilization of chemical solvents
- Bonding of the multi-material component without detrimental delamination
- Negligible corrosion of the multi-material component

## Future Application

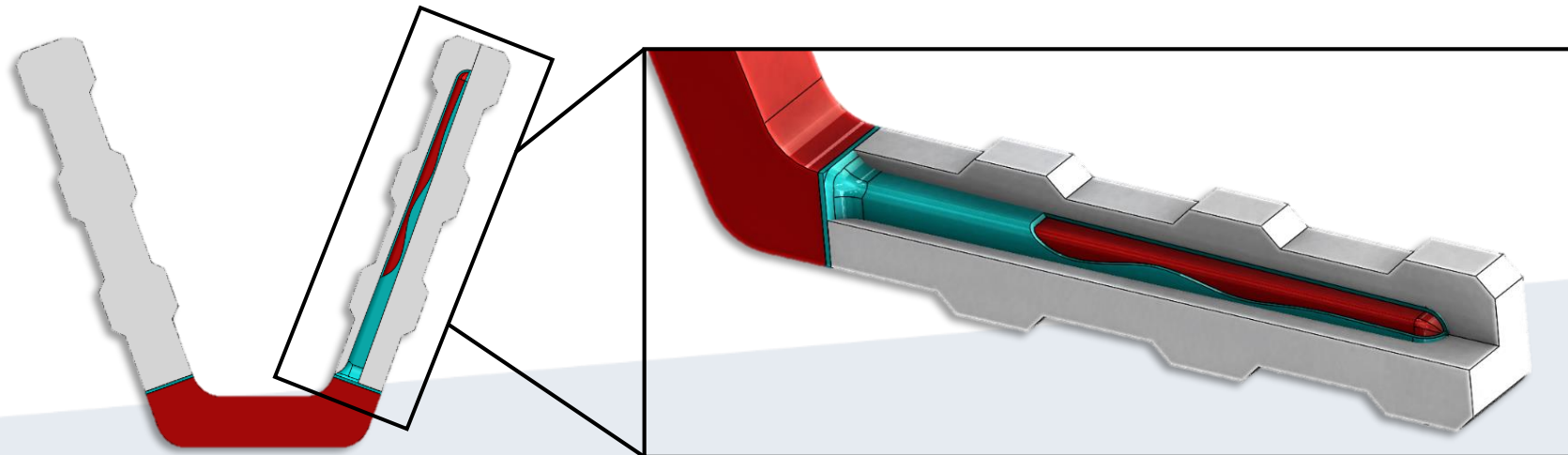



**TUBAF**  
Die Ressourcenuniversität.  
Seit 1765.

**XERION**  
BERLIN • LABORATORIES



Institut für Keramik,  
Feuerfest und  
Verbundwerkstoffe

## Patricia Kaiser

Institute of Ceramics, Refractories and Composite Materials

Agricolastraße 17, 09599 Freiberg

Tel.: +49(0)3731 39-2309

[patricia.kaiser@ikfvw.tu-freiberg.de](mailto:patricia.kaiser@ikfvw.tu-freiberg.de)

# THANK YOU FOR YOUR ATTENTION!



Freiberger Feuerfestforum

13.12.2023

**#tubaf**